

GENT

by Honeywell

5.2: VIGILON COMPACT FIRE DETECTION

LCD Repeat Panel

The LCD repeat panel indicates Fire, Fault and Disablement information on a 40 character display, either directly as events occur or by accessing the logs via dedicated keys.

A maximum of 4 Repeat Panels can be connected to a Vigilon Compact control panel.



Vigilon Compact Repeat Panel

TECHNICAL SPECIFICATION	
Type	LCD Repeat Panel (Indication Only)
Ingress Protection	IP30
Supply Voltage	21 – 30V dc
Power Consumption	Approx 30 mA
Approx Weight	0.75 Kg
Operating Temperature	0°C to +45°C
Communication ports	1x RS485 to communicate with the main control panel
Cable Entry	Top and rear knockins
Approvals	N/A

Dimensions (mm)

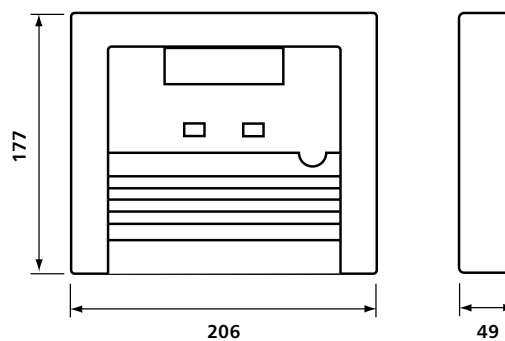

Wiring Details – LCD Repeat Panel (indication only)

Max Cable Length 1000M

One LCD repeat panel can be powered from the control panel, additional repeat indicators must be powered from an additional power supply.

The communication link to the panel is monitored, so if power to the repeat indicators fails the fault will be reported at the control panel.

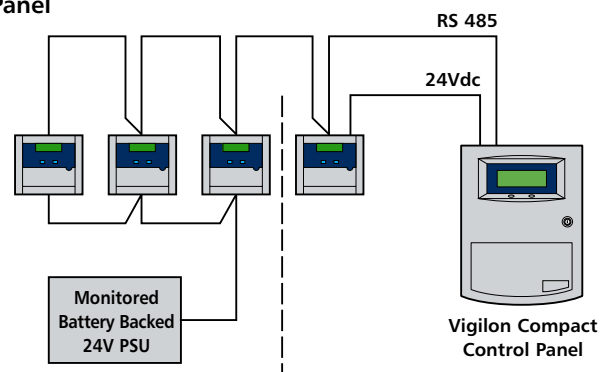

ORDER CODES

LCD Repeat panel

COMPACT-RPT