

6: VIGILON LOOP DEVICES

Beam Sensors

GENT

by Honeywell



Beam Sensor (Pair)

Beam sensors are suitable for large open areas where installation of single point detectors may be difficult or uneconomical. These detectors come in pairs, one of which emits an infra-red beam, detected by the other unit. If the beam is broken by smoke, the sensor is triggered.

This model employs 'True' analogue detection techniques whereby other interruptions, caused by people or shadows, will be discounted.

TECHNICAL SPECIFICATION	
Max. Quantity per Loop	16 pairs
Approx Weight	0.6Kg per pair
Ingress Protection	IP42
Operating Temperature	0°C to 50°C
Relevant Standards	BS 5839- 5
Beam Length	2 - 100m
Mounting Height	25 - 40m
Device Load Factor	2

Dimensions (mm)

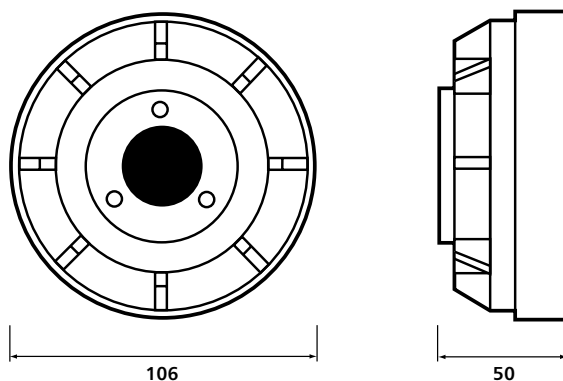

ORDER CODES

Beam Sensor (Pair)	34740
--------------------	-------

Brackets required (2 per pair)

Angle bracket	34741-01
Angle bracket IP55	34741-90
Parallel bracket	34741-03